



27. February 2020

SUMMARY OF PRODUCT CHARACTERISTICS

for

Ultra-TechneKow, radionuclide generator.

1 NAME OF THE MEDICINAL PRODUCT

Ultra-TechneKow FM

2. QUALITATIVE AND QUANTITATIVE COMPOSITION

Sodium pertechnetate (^{99m}Tc) injection is produced by means of a ($^{99}\text{Mo}/^{99m}\text{Tc}$) generator. Technetium (^{99m}Tc) decays with the emission of gamma radiation with a mean energy of 140 keV and a half-life of 6.01 hours to technetium (^{99}Tc) which, in view of its long half-life of 2.13×10^5 years can be regarded as quasi stable.

The radionuclide generator containing the parent isotope ^{99}Mo , adsorbed on a chromatographic column delivers sodium pertechnetate (^{99m}Tc) injection in sterile solution.

The ^{99}Mo on the column is in equilibrium with the formed daughter isotope ^{99m}Tc . The generators are supplied with the following ^{99}Mo activity amounts at activity reference time which deliver the following technetium (^{99m}Tc) amounts, assuming a 100% theoretical elution yield and 24 hours' time from previous elution and taking into account that branching ratio of ^{99}Mo is about 87%:

^{99m}Tc activity (maximum theoretical elutable activity at ART, 06.00 h CET)	1.90	3.81	5.71	7.62	9.53	11.43	15.24	19.05	22.86	26.67	30.48	38.10	GBq
^{99}Mo activity (at ART, 06.00 h CET)	2.15	4.30	6.45	8.60	10.75	12.90	17.20	21.50	25.80	30.10	34.40	43.00	GBq

The technetium (^{99m}Tc) amounts available by a single elution depend on the real yields of the kind of generator used itself declared by manufacturer and approved by National Competent Authority.

Excipient(s) with known effect

Each mL of sodium pertechnetate (^{99m}Tc) solution contains 3.5 mg of sodium.

For the full list of excipients, see section 6.1.

3. PHARMACEUTICAL FORM

Radionuclide generator.

4. CLINICAL PARTICULARS

4.1 Therapeutic indications

This medicinal product is for diagnostic use only.

The eluate from the radionuclide generator (sodium pertechnetate (^{99m}Tc) injection is indicated for:

- labelling of various kits for radiopharmaceutical preparation developed and approved for radiolabelling with such solution
- Thyroid scintigraphy: direct imaging and measurement of thyroid uptake to give information on the size, position, nodularity and function of the gland in thyroid disease
- Salivary gland scintigraphy: diagnosis of chronic sialadenitis (e.g. (Sjögren's Syndrom) as well as assessment of salivary gland function and duct patency in salivary glands disorders and monitoring of the response to therapeutic interventions (in particular radio iodine therapy)
- Location of ectopic gastric mucosa (Meckel's diverticulum)
- Lacrimal duct scintigraphy: to assess functional disorders of lacrimation and monitoring of the response to therapeutic interventions

4.2 Posology and method of administration

Posology

If sodium pertechnetate (^{99m}Tc) is administered intravenously, activities may vary widely according to the clinical information required and the equipment employed. The injection of activities greater than local DRLs (Diagnostic Reference Levels) should be justified for certain indications. Recommended activities are as follows:

Adults (70 kg) and elderly population:

- Thyroid scintigraphy: 20 - 80 MBq
- Salivary gland scintigraphy: 30 to 150 MBq for static images up to 370 MBq for dynamic images
- Meckel's diverticulum scintigraphy: 300 - 400 MBq
- Lacrimal duct scintigraphy: 2-4 MBq per drop per eye

Renal impairment

Careful consideration of the activity to be administered is required since an increased radiation exposure is possible in these patients.

Paediatric population

The use in children and adolescents has to be considered carefully, based upon clinical needs and assessing the risk/benefit ratio in this patient group.

The activity to be administered to children and adolescents must be adapted and may be calculated according to the recommendations of the European Association of Nuclear Medicine (EANM) paediatric dosage card; the activity administered to children and to adolescents may be calculated by multiplying a baseline activity (for calculation purposes) by the weight-dependent correction factor given in the table below (see Table 1).

$$A[\text{MBq}]_{\text{Administered}} = \text{Baseline Activity} \times \text{Multiple}$$

Thyroid scintigraphy: Activity administered [MBq] = 5.6 MBq x correction factor (Table 1). A minimal activity of 10 MBq is necessary for obtaining images of sufficient quality.

Identification/location of ectopic gastric mucosa: Activity administered [MBq] = 10.5 MBq x correction factor (Table 1). A minimal activity of 20 MBq is necessary in order to obtain images of sufficient quality.

Table 1: Weight-dependent correction factors in the paediatric population (for thyroid scintigraphy and identification/location of ectopic gastric mucosa) according to the EANM-2014 guidelines

Weight [kg]	Multiple	Weight [kg]	Multiple	Weight [kg]	Multiple
3	1	22	5.29	42	9.14
4	1.14	24	5.71	44	9.57
6	1.71	26	6.14	46	10.00
8	2.14	28	6.43	48	10.29
10	2.71	30	6.86	50	10.71
12	3.14	32	7.29	52-54	11.29
14	3.57	34	7.72	56-58	12.00
16	4.00	36	8.00	60-62	12.71
18	4.43	38	8.43	64-66	13.43
20	4.86	40	8.86	68	14.00

Salivary gland scintigraphy: The Paediatric Task Group of EANM (1990) recommends that the activity to be administered to a child should be calculated from the body weight according to the table below (see Table 2) with a minimum dose of 10 MBq in order to obtain images of sufficient quality.

Table 2: Weight-dependent correction factor in the paediatric population (for salivary gland scintigraphy) according to EANM 1990 recommendations

Weight [kg]	Factor	Weight [kg]	Factor	Weight [kg]	Factor
3	0.1	22	0.50	42	0.78
4	0.14	24	0.53	44	0.80
6	0.19	26	0.56	46	0.82
8	0.23	28	0.58	48	0.85
10	0.27	30	0.62	50	0.88
12	0.32	32	0.65	52-54	0.90
14	0.36	34	0.68	56-58	0.92
16	0.40	36	0.71	60-62	0.96
18	0.44	38	0.73	64-66	0.98
20	0.46	40	0.76	68	0.99

Lacrimal duct scintigraphy: Recommended activities apply as well for adults as for children.

Method of administration

For intravenous or ocular use.

For multidose use.

For instructions on extemporaneous preparation of the medicinal product before administration, see section 12.

For patient preparation, see section 4.4.

In thyroid scintigraphy, salivary gland scintigraphy and identification/location of ectopic gastric mucosa, the sodium pertechnetate (^{99m}Tc) solution is administered by intravenous injection.

In lacrimal duct scintigraphy, drops are instilled in each eye (ocular use).

Image acquisition

Thyroid scintigraphy: 20 minutes after intravenous injection.

Salivary gland scintigraphy: immediately after intravenous injection and at regular intervals for 15 minutes.

Identification/location of ectopic gastric mucosa (Meckel Diverticulum): immediately after intravenous injection and at regular intervals for 30 minutes.

Lacrimal duct scintigraphy: dynamic acquisition within 2 minutes after instillation, followed by static images acquired at regular intervals within 20 minutes.

4.3 Contraindications

Hypersensitivity to the active substance or any of the excipients listed in section 6.1.

4.4 Special warnings and precautions for use

Potential for hypersensitivity or anaphylactic reactions

If hypersensitivity or anaphylactic reactions occur, the administration of the medicinal product must be discontinued immediately and intravenous treatment initiated, if necessary. To enable immediate action in emergencies, the necessary medicinal products and equipment such as endotracheal tube and ventilator must be immediately available.

Individual benefit/risk justification

For each patient, the radiation exposure must be justifiable by the likely benefit. The activity administered should in every case be as low as reasonably achievable to obtain the required diagnostic information.

Renal impairment

Careful consideration of the benefit risk ratio in these patients is required since an increased radiation exposure is possible.

Paediatric population

For information on the use in paediatric population, see section 4.2.

Careful consideration of the indication is required since the effective dose per MBq is higher than in adults (see section 11).

Thyroid blocking is of special importance in the paediatric patient population except for thyroid scintigraphy.

Patient preparation

Pre-treatment of patients with thyroid-blocking medicinal products may be necessary for certain indications.

The patient should be well hydrated before the start of the examination and urged to void as

often as possible during the first hours after the examination in order to reduce radiation.

To avoid false positives or to minimise irradiation by reduction of pertechnetate accumulation in the thyroid and salivary glands, a thyroid blocking agent should be given prior to lacrimal duct scintigraphy or Meckel's diverticulum scintigraphy. Conversely a thyroid blocking agent must NOT be used before thyroid, parathyroid or salivary glands scintigraphy.

Before the application of sodium (^{99m}Tc) pertechnetate solution for scintigraphy of Meckel's diverticulum the patient must keep an empty stomach for 3 to 4 hours to reduce intestinal peristalsis.

After in vivo labelling of erythrocytes using stannous ions for reduction sodium pertechnetate (^{99m}Tc) is primarily built into erythrocytes, therefore Meckel's scintigraphy should be performed before or some days after in vivo labelling of erythrocytes.

After the procedure

Close contact with infants and pregnant women should be restricted during 12 hours.

Specific warnings

Sodium pertechnetate (^{99m}Tc) solution for injection contains 3.5 mg/mL of sodium.

Depending on the time when the injection is administered, the content of sodium given to the patient may in some cases be greater than 1 mmol (23 mg). This should be taken into account in patient on low sodium diet.

When sodium pertechnetate (^{99m}Tc) solution is used for labelling of a kit, the determination of the overall sodium content must take into account the sodium derived from the eluate and the kit. Please refer to the package leaflet of the kit.

In salivary gland scintigraphy a lower specificity of the method should be expected compared to magnetic resonance sialography.

For precautions with respect to environmental hazard, see section 6.6.

4.5 Interaction with other medicinal products and other forms of interaction

Atropine, isoprenaline and analgesics may cause a delay of gastric emptying and thereby cause a redistribution of (^{99m}Tc) pertechnetate in abdominal imaging.

Administration of laxatives should be withheld since they irritate the gastrointestinal tract.

Contrast-enhanced studies (e.g. barium) and upper gastro-intestinal examination should be avoided within 48h prior to administration of pertechnetate (^{99m}Tc) for Meckel's diverticulum scintigraphy.

Many pharmacological medicinal products are known to modify the thyroid uptake.

- antithyroid medicinal products (e.g. carbimazole or other imidazole derivatives such as propylthiouracil), salicylates, steroids, sodium nitroprusside, sodium sulfobromophthalein, perchlorate should be withheld for 1 week prior thyroid scintigraphy
- phenylbutazone and expectorants should be withheld for 2 weeks
- natural or synthetic thyroid preparations (e.g. sodium thyroxine, sodium liothyronine, thyroid extract) should be withheld for 2-3 weeks
- amiodarone, benzodiazepines, lithium should be withheld for 4 weeks
- intravenous contrast agents should not have been administered within 1-2 months.

4.6 Pregnancy and lactation

Women of childbearing potential

When an administration of radiopharmaceuticals to a woman of childbearing potential is intended, it is important to determine whether or not she is pregnant. Any woman who has missed a period should be assumed to be pregnant until proven otherwise. If in doubt about her potential pregnancy ((if the woman has missed a period, if the period is very irregular, etc.), alternative techniques not using ionising radiation (if there are any) should be offered to the patient.

Pregnancy

Administration of pertechnetate (^{99m}Tc) to a mother who is known to be pregnant should be justified by medical need and a positive individual benefit risk assessment for the mother and the foetus.

Alternative non-irradiating diagnostic modalities should be taken into account.

^{99m}Tc (as free pertechnetate) has been shown to cross the placental barrier.

Breast-feeding

Before administering a radiopharmaceuticals to a woman who is breast-feeding, consideration should be given of delaying the administration of radionuclide until the mother has ceased breast-feeding and as to what is the most appropriate choice of radiopharmaceuticals, bearing in mind the secretion of activity in breast milk. If the administration is considered necessary, breast-feeding should be interrupted for 12 hours post administration and the expressed feeds discarded.

Close contact with infants should be restricted during this period.

4.7 Effects on ability to drive and use machines

Sodium pertechnetate (^{99m}Tc) solution has no influence on the ability to drive and use machines.

4.8 Undesirable effects

Summary of the safety profile

Information on adverse reactions is available from spontaneous reporting. The reported reaction types are anaphylactoid reactions, vegetative reactions, as well as different kinds of injection site reactions. Sodium pertechnetate (^{99m}Tc) from the Ultra-TechneKow FM radionuclide generator is used for radioactive labeling of a variety of compounds. These medicinal products generally have a higher potential for adverse reactions than ^{99m}Tc , and therefore the reported adverse reactions are rather related to the labelled compounds than to ^{99m}Tc . The possible types of adverse reactions following intravenous administration of a ^{99m}Tc -labelled pharmaceutical preparation will be dependent on the specific compound being used. Such information can be found in the SmPC of the kit used for radiopharmaceutical preparation.

Tabulated list of adverse reactions

The frequency of undesirable effects is defined as follows:

Not known (cannot be estimated from the available data).

<u>Immune system disorders</u> Frequency not known*: Anaphylactoid reactions (e.g. dyspnoea, coma, urticaria, erythema, rash, pruritus, oedema at various location e.g. face oedema)
<u>Nervous system disorders</u> Frequency not known*: Vasovagal reactions (e.g. syncope, tachycardia, bradycardia, dizziness, headache, vision blurred, flushing)
<u>Gastrointestinal disorders</u> Frequency not known*: Vomiting, nausea, diarrhoea
<u>General disorders and administration site conditions</u> Frequency not known*: Injection site reactions (e.g. Cellulitis, pain, erythema, swelling)

* Adverse reactions derived from spontaneous reporting

Exposure to ionising radiation is linked with cancer induction and a potential for development of hereditary defects. As the effective dose is 5.2 mSv when the maximal recommended activity of 400 MBq is administered these adverse reactions are expected to occur with a low probability.

Description of selected adverse reactions

Anaphylactoid reactions (e.g. dyspnoea, coma, urticaria, erythema, rash, pruritus, oedema at various

locations [e.g. face oedema])

Anaphylactoid reactions have been reported following intravenous injection of sodium pertechnetate (^{99m}Tc) and include various skin or respiratory symptoms like skin irritations, oedema, or dyspnoea.

Vegetative reactions (nervous system and gastrointestinal disorders)

Single cases of severe vegetative reactions have been reported, however, most of the reported vegetative reactions include gastrointestinal reactions like nausea or vomiting. Other reports include vasovagal reactions like headache or dizziness. Vegetative reactions are rather considered to be related to the examinational setting than to technetium (^{99m}Tc), especially in anxious patients.

General disorders and administration site conditions

Other reports describe local injection site reactions. Such reactions are related to extravasation of the radioactive material during the injection, and the reported reactions rank from local swelling up to cellulitis. Depending on the administered radioactivity and the labeled compound, extended extravasation may necessitate surgical treatment.

Reporting of suspected adverse reactions

Reporting suspected adverse reactions after authorisation of the medicinal product is important. It allows continued monitoring of the benefit/risk balance of the medicinal product. Healthcare professionals are asked to report any suspected adverse reactions via:

Lægemiddelstyrelsen
Axel Heides Gade 1
DK-2300 København S
Websted: www.meldenbivirkning.dk

4.9 Overdose

In the event of the administration of a radiation overdose with sodium pertechnetate (^{99m}Tc), the absorbed dose should be reduced where possible by increasing the elimination of the radionuclide from the body by defaecation, forced diuresis and frequent bladder voiding. The uptake in the thyroid, salivary glands and the gastric mucosa can be significantly reduced when sodium or potassium perchlorate is given immediately after an accidentally high dose of sodium pertechnetate (^{99m}Tc) was administered.

5. PHARMACOLOGICAL PROPERTIES

5.1 Pharmacodynamic properties

Pharmacotherapeutic group: Diagnostic radiopharmaceuticals, various thyroid diagnostic radiopharmaceuticals, ATC code: V09FX01

No pharmacological activity has been observed in the range of doses administered for diagnostic purposes.

5.2 Pharmacokinetic properties

Distribution

The pertechnetate ion has similar biological distribution to iodide and perchlorate ions, concentrating temporarily in salivary glands, choroid plexus, stomach (gastric mucosa) and in the thyroid gland, from which it is eliminated unchanged. The pertechnetate ion also tends to concentrate in areas with increased vascularisation or with abnormal vascular permeability, particularly when pre-treatment with blocking agents inhibits uptake in glandular structures. With intact blood brain barrier, sodium pertechnetate (^{99m}Tc) does not penetrate into the brain tissue.

Organ uptake

In the blood 70-80% of the intravenously injected sodium pertechnetate (^{99m}Tc) is bound to proteins, primarily in an unspecific way to albumin. The unbound fraction (20-30%) accumulates temporarily in thyroid and salivary glands, stomach and nasal mucous membranes as well as in the plexus chorioideus.

Sodium pertechnetate (^{99m}Tc) in contrast to iodine, nevertheless, is neither used for the thyroid hormone synthesis (organification), nor absorbed in the small intestine. In the thyroid the maximum accumulation, depending on functional status and iodine saturation (in euthyroidism approx. 0.3-3%, in hyperthyroidism and iodine depletion up to 25%) is reached about 20 min after injection and then decreases quickly. This also applies for the stomach mucous membrane parietal cells and the salivary glands acinar cells.

In contrast to the thyroid which releases sodium pertechnetate (^{99m}Tc) in the bloodstream the salivary glands and the stomach secrete sodium pertechnetate (^{99m}Tc) in the saliva and gastric juice, respectively. The accumulation by the salivary gland lies in the magnitude of 0.5% of the applied activity with the maximum reached after about 20 minutes. One hour after injection, the concentration in the saliva is about 10-30 fold higher than in the plasma. The excretion can be accelerated by lemon juice or by stimulation of the parasympathetic nerve system, the absorption is reduced by perchlorate.

Elimination

Half life in plasma is approximately 3 hours. Sodium pertechnetate (^{99m}Tc) is not metabolised in the organism. One fraction is eliminated very quickly renally, the rest more slowly via faeces, salivary and tear liquid. Excretion during the first 24 hours following administration is mainly urinary (approximately 25%) with faecal excretion occurring over the next 48 hours. Approximately 50% of the administered activity is excreted within the first 50 hours. When selective uptake of pertechnetate (^{99m}Tc) in glandular structures is inhibited by the preadministration of blocking agents, excretion follows the same pathways but there is a higher renal clearance.

The above data are not valid when sodium pertechnetate (^{99m}Tc) is used for labelling of another radiopharmaceutical.

5.3 Preclinical safety data

There is no information on acute, subacute and chronic toxicity from single or repeated dose administration. The quantity of sodium pertechnetate (^{99m}Tc) administered during clinical diagnostic procedures is very small and apart from allergic reactions, no other adverse reactions have been reported.

This medicinal product is not intended for regular or continuous administration.

Mutagenicity studies and long-term carcinogenicity studies have not been carried out.

Reproductive toxicity

Placental transfer of ^{99m}Tc from intravenously administered sodium pertechnetate (^{99m}Tc) has been studied in mice. The pregnant uterus was found to contain as much as 60% of the injected ^{99m}Tc when administered without perchlorate pre-administration. Studies performed on pregnant mice during gestation, gestation and lactation, and lactation alone showed changes in progeny which included weight reduction, hairlessness and sterility.

6. PHARMACEUTICAL PARTICULARS

6.1 List of excipients

- Sodium chloride
- Water for injections

6.2 Incompatibilities

This medicinal product must not be mixed with other medicinal products except for those mentioned in section 12.

6.3 Shelf life

Generator: 21 days from the start of manufacturing and 9 days after activity reference time (ART).

The calibration date and the expiry date are stated on the label.

Sodium pertechnetate (^{99m}Tc) Eluate: after elution, use within 8 hours. The eluate does not require any special storage conditions.

Technevials for elution vials (Techne vials): 3 years

Eluent vial: 3 years

6.4 Special precautions for storage

Generator: do not store above 25°C.

Eluate: for storage conditions after elution of the medicinal product, see section 6.3.

Generators must be kept in an Ultra-TechneKow Safe (with sufficient lead protection) or behind an adequate laboratory shield.

Storage of radiopharmaceuticals should be in accordance with national regulation on radioactive materials.

6.5 Nature and contents of container

Generator

The generator consists of a cartridge containing an aluminiumoxide column charged with ^{99}Mo and locked between two filters. One side of the cartridge is connected to the shielded, sterile supply needle in the eluent holder. The other side is connected to the similarly shielded, sterile outlet needle in the elution station. A second sterile needle in the eluent holder serves to eliminate the underpressure in the eluent vial under sterile conditions. The generator column is shielded by sufficient lead, depending on the ^{99}Mo activity. The shielded generator with the built-in station and the eluent holder are packed in a hermetically sealed tin, which is also the package. Elution occurs by placing the eluent vial on the needles in the eluent holder, followed by complete or partial filling of evacuated vials.

Accessories

The first time an Ultra-TechneKow FM is supplied, it comes with:

- 1 TechneVial shield or UltraVial Shield
- 1 Sterile vial shielding, unless supplied with the Ultra-Technekow Safe.

Each Ultra-TechneKow FM is supplied with:

- 7 TechneVials, sterile, evacuated vials of 5, 11 or 25 ml
- 1 Sterile vial is provided with the elution set.
- 1 Eluent vial, 100 ml of sterile, physiological salt solution
- 7 Disinfection swabs
- 7 Labels with the radioactivity symbol.

6.6 Special precautions for disposal and other handling

General warnings

Radiopharmaceuticals should be received, used and administered only by authorised persons in designated clinical settings. Their receipt, storage, use, transfer and disposal are subject to the regulations and/or appropriate licences of the competent official organisation.

Radiopharmaceuticals should be prepared in a manner which satisfies both radiation safety and pharmaceutical quality requirements. Appropriate aseptic precautions should be taken.

If at any time the integrity of the generator or the vial with the eluted solution is compromised, it should not be used.

Administration procedures should be carried out in a way to minimise risk of contamination of the medicinal product and irradiation of the operators. Adequate shielding is mandatory.

The administration of radiopharmaceuticals creates risks for other persons from external radiation or contamination from spills of urine, vomiting, etc. Radiation protection precautions in accordance with national regulations must therefore be taken.

The residual activity of the generator must be estimated before disposal.

Any unused medicinal product or waste material should be disposed of in accordance with local requirements.

7. **MARKETING AUTHORISATION HOLDER**

Curium Netherlands B.V.
Westerduinweg 3
1755 LE Petten
The Netherlands

8. **MARKETING AUTHORISATION NUMBER**

DK R 1114

9. **DATE OF FIRST AUTHORISATION/RENEWAL OF THE AUTHORISATION**

31 January 1995

10. **DATE OF REVISION OF THE TEXT**

27. February 2020

11. **DOSIMETRY**

The data listed below are from ICRP 80 and are calculated according to the following assumptions:

(I) Without pre-treatment with a blocking agent:

Organ	Absorbed dose per administered unit of activity (mGy/MBq)				
	Adults	15 years	10 years	5 years	1 year
Adrenal glands	0.0037	0.0047	0.0072	0.011	0.019
Bladder wall	0.018	0.023	0.030	0.033	0.060

Bone surfaces	0.0054	0.0066	0.0097	0.014	0.026
Brain	0.0020	0.0025	0.0041	0.0066	0.012
Breasts	0.0018	0.0023	0.0034	0.0056	0.011
Gallbladder	0.0074	0.0099	0.016	0.023	0.035
Gastrointestinal tract					
- Stomach wall	0.026	0.034	0.048	0.078	0.16
- Small intestine	0.016	0.020	0.031	0.047	0.082
- Colon	0.042	0.054	0.088	0.14	0.27
- Ascending colon wall	0.057	0.073	0.12	0.20	0.38
- Descending colon wall	0.021	0.028	0.045	0.072	0.13
Heart	0.0031	0.0040	0.0061	0.0092	0.017
Kidneys	0.0050	0.0060	0.0087	0.013	0.021
Liver	0.0038	0.0048	0.0081	0.013	0.022
Lungs	0.0026	0.0034	0.0051	0.0079	0.014
Muscles	0.0032	0.0040	0.0060	0.0090	0.016
Oesophagus	0.0024	0.0032	0.0047	0.0075	0.014
Ovaries	0.010	0.013	0.018	0.026	0.045
Pancreas	0.0056	0.0073	0.011	0.016	0.027
Red bone marrow	0.0036	0.0045	0.0066	0.0090	0.015
Salivary glands	0.0093	0.012	0.017	0.024	0.039
Skin	0.0018	0.0022	0.0035	0.0056	0.010
Spleen	0.0043	0.0054	0.0081	0.012	0.021
Testes	0.0028	0.0037	0.0058	0.0087	0.016
Thymus	0.0024	0.0032	0.0047	0.0075	0.014
Thyroid	0.022	0.036	0.055	0.12	0.22
Uterus	0.0081	0.010	0.015	0.022	0.037
Other tissue	0.0035	0.0043	0.0064	0.0096	0.017
Effective dose (mSv/MBq)	0.013	0.017	0.026	0.042	0.079

(II) With pre-treatment with a blocking agent:

Organ	Absorbed dose per administered unit of activity (mGy/MBq) when blocking agents are administered				
	Adults	15 years	10 years	5 years	1 year
Adrenal glands	0.0029	0.0037	0.0056	0.0086	0.016
Bladder wall	0.030	0.038	0.048	0.050	0.091
Bone surfaces	0.0044	0.0054	0.0081	0.012	0.022
Brain	0.0020	0.0026	0.0042	0.0071	0.012
Breasts	0.0017	0.0022	0.0032	0.0052	0.010
Gallbladder	0.0030	0.0042	0.0070	0.010	0.013
Gastrointestinal tract					
- Stomach wall	0.0027	0.0036	0.0059	0.0086	0.015

Organ	Absorbed dose per administered unit of activity (mGy/MBq) when blocking agents are administered				
- Small intestine	0.0035	0.0044	0.0067	0.010	0.018
- Colon	0.0036	0.0048	0.0071	0.010	0.018
- Ascending colon wall	0.0032	0.0043	0.0064	0.010	0.017
Descending colon wall	0.0042	0.0054	0.0081	0.011	0.019
Heart	0.0027	0.0034	0.0052	0.0081	0.014
Kidneys	0.0044	0.0054	0.0077	0.011	0.019
Liver	0.0026	0.0034	0.0053	0.0082	0.015
Lungs	0.0023	0.0031	0.0046	0.0074	0.013
Muscles	0.0025	0.0031	0.0047	0.0072	0.013
Oesophagus	0.0024	0.0031	0.0046	0.0075	0.014
Ovaries	0.0043	0.0054	0.0078	0.011	0.019
Pancreas	0.0030	0.0039	0.0059	0.0093	0.016
Red bone marrow	0.0025	0.0032	0.0049	0.0072	0.013
Skin	0.0016	0.0020	0.0032	0.0052	0.0097
Spleen	0.0026	0.0034	0.0054	0.0083	0.015
Testes	0.0030	0.0040	0.0060	0.0087	0.016
Thymus	0.0024	0.0031	0.0046	0.0075	0.014
Thyroid	0.0024	0.0031	0.0050	0.0084	0.015
Uterus	0.0060	0.0073	0.011	0.014	0.023
Other tissue	0.0025	0.0031	0.0048	0.0073	0.013
Effective dose (mSv/MBq)	0.0042	0.0054	0.0077	0.011	0.019

The effective dose resulting from the intravenous administration of 400 MBq of sodium pertechnetate (^{99m}Tc) to an adult weighing 70 kg is about 5.2 mSv.

After pretreatment of patients with a blocking agent and administration of 400 MBq of sodium pertechnetate (^{99m}Tc) to an adult weighing 70 kg the effective dose is 1.7 mSv.

The radiation dose absorbed by the lens of the eye following administration of sodium pertechnetate (^{99m}Tc) for lacrimal duct scintigraphy is estimated to be 0.038 mGy/MBq. This results in an effective dose equivalent of less than 0.01 mSv for an administered activity of 4 MBq.

The specified radiation exposure is only applicable if all organs accumulating sodium pertechnetate (^{99m}Tc) will function normally. Hyper/hypofunction (e.g. of the thyroid, gastric mucosa or kidney) and extended processes with impairment to the blood-brain-barrier or renal elimination disorders, may result in changes to the radiation exposure, locally even in strong increases of it.

The surface dose rates and the accumulated dose depends on many factors. Overall, radiation measurement on the environment and during work are critical and should be practised.

12. INSTRUCTIONS FOR PREPARATION OF RADIOPHARMACEUTICALS

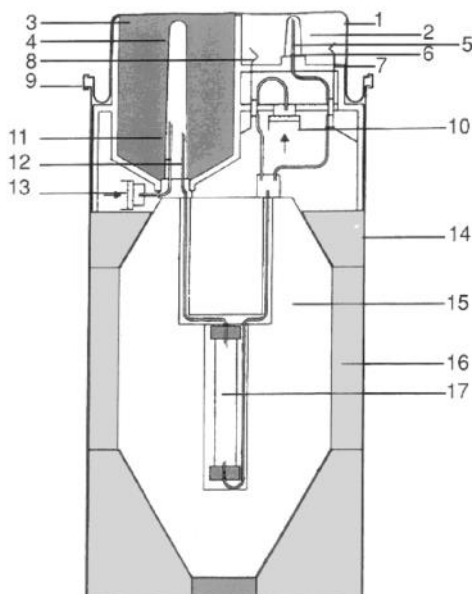

Schematic of the Ultra-TechneKow FM:

- 1 Top cover
- 2 Elution station
- 3 Eluent vial chamber
- 4 Plastic cover for eluent needle
- 5 Rubber cover for eluate needle
- 6 Eluate outlet needle
- 7 Safety valve
- 8 Valve for partial elution
- 9 Lever closing ring
- 10 Air filter for partial elution
- 11 Inlet needle for sterile air
- 12 Eluent inlet needle
- 13 Air filter for eluent bottle
- 14 Containment
- 15 Lead shield
- 16 Support for lead shield
- 17 Generator column

Instructions for use

The elution must be carried out in an area capable of maintaining the sterility of the generator.

Preparation

- 1 Remove the seal, open the lever-closing ring and store it together with the top cover.
- 2 Put the Ultra-TechneKow FM in the Ultra-TechneKow SAFE or behind any other suitable laboratory shielding with the elution station facing forward.

NB The needles are sterile beneath their covers and the generator underneath the top is clean, therefore disinfection with liberal amounts of disinfectants containing alcohol is undesirable and moreover may influence the pertechnetate (^{99m}Tc) yield unfavourably.

- 3 Remove the flip-off cover from the capsule of the eluent vial, disinfect the stopper, remove (and store) the plastic cover of the inlet needle and lower the eluent vial into its holder.
- 4 Remove the flip-off cover from the capsule of the sterile vial and put it into the sterile vial shielding.
- 5 Remove (and store) the rubber needle protection from the outlet needle and lower the shielded sterile vial into the elution station.

Elution

- 1 Remove the flip-off cover from the capsule of the required TechneVial, disinfect the stopper, let the disinfectant evaporate completely and put the vial into the UltraVial Shielding. (The TechneVial contains some residual water as a result of the sterilisation process.)
- 2 Replace the shielded sterile vial by the UltraVial Shield, ensure the lead glass window faces front.
- 3 Elution starts. The process can be interrupted depending on the required elution volume (Pertechnetate (^{99m}Tc) concentration/ml). Elution is **always** ended by giving the UltraVial Shield a quarter turn, pushing it down and waiting for a few seconds (this causes the TechneVial to be filled with sterile air).
- 4 Replace the TechneVial Shielding by a shielded unused sterile vial.

Never interrupt elution by lifting the TechneVial Shield without the quarter turn!

Eluates that are not clear or colourless must be rejected.

Disposal of waste and return of the generator

- 1 Remove and dispose of the used sterile vial and the eluent vial.
- 2 Replace the original needle cover back on the inlet needles.
- 3 Elute the remaining millilitres of fluid from the generator (see under elution). The generator is now dry.
- 4 Replace the original outlet needle cover on the outlet needle.
- 5 Close the generator system with its top cover and lever closing ring.
- 6 Store the generator in a suitable place for decay to a level acceptable for disposal.

NB: In some countries the possibility exists to return expired generators. Consult the local representative for such a possibility or for details of dismantling.

Elution of the generator must be performed in premises complying with the national regulations concerning the safety of use of radioactive products.

The solution eluted is a clear and colourless sodium pertechnetate (^{99m}Tc) solution, with a pH between 4 and 8 and a radiochemical purity equal to or greater than 99%.

When sodium pertechnetate (^{99m}Tc) solution is used for kit labelling, please refer to the package leaflet of the concerned kit.

Quality control

Radioactivity and molybdenum (^{99}Mo) break-through must be checked before administration.

The test for molybdenum (^{99}Mo) break-through can be performed either according to Ph. Eur. or to any other validated methods able to determine molybdenum (^{99}Mo) content below 0.1% of total radioactivity at the date and hour of administration.

The first eluate obtained from this generator can be normally used, unless otherwise specified. Eluates even eluted later than 24 hours from the last elution can be used for kit labelling, unless it is excluded by the specifications of the relevant kit SmPC.