

## SUMMARY OF PRODUCT CHARACTERISTICS

### 1. NAME OF THE MEDICINAL PRODUCT

Ultra-TechneKow FM

### 2. QUALITATIVE AND QUANTITATIVE COMPOSITION

Technetium ( $^{99m}\text{Tc}$ ) is produced by means of a ( $^{99}\text{Mo}/^{99m}\text{Tc}$ ) generator and decays with the emission of gamma radiation with a mean energy of 140 keV and a half-life of 6 hours to technetium ( $^{99}\text{Tc}$ ) which, in view of its long half-life of  $2.13 \times 10^5$  years can be regarded as quasi stable. A sterile generator containing the parent isotope  $^{99}\text{Mo}$ , adsorbed to an aluminium oxide column. The  $^{99}\text{Mo}$  on the column is in equilibrium with the formed daughter isotope  $^{99m}\text{Tc}$ . The generators are supplied with the following  $^{99}\text{Mo}$  activity amounts at activity reference time:

GBq	GBq
2.15	17.20
4.30	21.50
6.45	25.80
8.60	30.10
10.75	34.40
12.90	43.00

For a full list of excipients, see section 6.1.

### 3. PRODUCT DESCRIPTION

The generator consists of a cartridge containing a column packed with Mo-99 adsorbed on aluminium oxide locked between two filters. One side of the cartridge is connected to the shielded, sterile supply needle in the eluent holder. The other side is connected to the similarly shielded, sterile outlet needle in the elution station. A second sterile needle in the eluent holder serves to eliminate the under pressure in the eluent vial under sterile conditions. The generator column is shielded by sufficient lead, depending on the Mo-99 activity. The shielded generator and the eluent holder are packed in an hermetically sealed tin, which is also the package. Elution occurs by placing the eluent vial on the needles in the eluent holder, followed by complete or partial filling of evacuated vial.

### 4. PHARMACEUTICAL FORM

Radionuclide generator.

### 5. CLINICAL PARTICULARS

#### 5.1 Therapeutic indications

This medicinal product is for diagnostic use only.

The eluate from the generator (Sodium Pertechnetate ( $^{99m}\text{Tc}$ ) Injection Ph. Eur.) may be used as a reagent for labelling of various carrier compounds supplied as kits or administered directly in-vivo.

A When administered intravenously, the sterile sodium pertechnetate ( $^{99m}\text{Tc}$ ) solution is used as a diagnostic aid in the following:

- **Thyroid scintigraphy:** direct imaging and measurement of thyroid uptake to give information on the size, position, nodularity and function of the gland in thyroid disease.
- **Salivary gland scintigraphy:** to assess salivary gland function and duct patency.
- **Location of ectopic gastric mucosa:** Meckel's diverticulum.
- **Cerebral scintigraphy:** to identify breaches in the blood-brain barrier caused by tumour, infarction, haemorrhage and oedema, when no other methods are available.

B When used in conjunction with pre-treatment with a reducing agent to effect technetium ( $^{99m}\text{Tc}$ )-labelling of red blood cells:

- **Cardiac and vascular scintigraphy**
  - angiocardioscintigraphy for:
    - \* evaluation of ventricular ejection fraction
    - \* evaluation of global and regional cardiac wall motion
    - \* myocardial phase imaging
  - organ perfusion or vascular abnormalities imaging
- **Diagnosis and localisation of occult gastrointestinal bleeding.**

C Following instillation of sterile sodium pertechnetate ( $^{99m}\text{Tc}$ ) solution into the eye:

- **Lacrimal duct scintigraphy:** to assess patency of tear ducts

## 5.2 Posology and method of administration

Sodium pertechnetate ( $^{99m}\text{Tc}$ ) is normally administered intravenously at activities which vary widely according to the clinical information required and the equipment employed. Other activities may be justifiable. It should be noted that in each country physicians should follow the Diagnostic Reference Levels and the rules set out by local law. Pre-treatment of patients with thyroid blocking agents or reducing agents may be necessary for certain indications. Recommended activities are as follows:

Adults and the elderly:

- Thyroid scintigraphy: 18.5-80 MBq  
Scintigraphy performed 20 minutes after intravenous injection.
- Salivary gland scintigraphy: 40 MBq  
Scintigraphy performed immediately after intravenous injection and at regular intervals up to 15 minutes.
- Meckel's diverticulum scintigraphy: 400 MBq  
Scintigraphy performed immediately after intravenous injection and at regular intervals

up to 30 minutes.

- **Brain scintigraphy:** 370-800 MBq  
Rapid sequential images are taken immediately within the first minute after intravenous administration; static images 1 to 4 hours later. Thyroid and choroid plexus should be blocked to avoid non-specific  $^{99m}\text{Tc}$  uptake.
- **Cardiac and vascular scintigraphy:** 740-925 MBq  
Red cells are labelled in-vivo or in-vitro by pretreating with a reducing agent. Dynamic images are taken in the first minute after intravenous administration, followed by regular images over 30 minutes.
- **Gastrointestinal bleeding:** 740-925 MBq  
Red cells are labelled in vivo or in vitro by pretreating with a reducing agent. Dynamic images are taken in the first minute after intravenous administration, followed by regular images at appropriate intervals for up to 24 hours.
- **Lacrimal duct scintigraphy:** 2-4 MBq each eye  
Drops are instilled into the eye and dynamic images are taken over 2 minutes, followed by static images at appropriate intervals over 20 minutes.

#### Children:

The activity for administration to children may be calculated from the recommended range of adult activity and adjusted according to body weight or surface area. However, the Paediatric Task Group of EANM recommends that the activity to be administered to a child should be calculated from the body weight according to the following table:

Fraction of adult dose:

3 kg = 0.1	4 kg = 0.14	6 kg = 0.19	8 kg = 0.23	10 kg = 0.27
12 kg = 0.32	14 kg = 0.36	16 kg = 0.40	18 kg = 0.44	20 kg = 0.46
22 kg = 0.50	24 kg = 0.53	26 kg = 0.56	28 kg = 0.58	30 kg = 0.62
32 kg = 0.65	34 kg = 0.68	36 kg = 0.71	38 kg = 0.73	40 kg = 0.76
42 kg = 0.78	44 kg = 0.80	46 kg = 0.82	48 kg = 0.85	50 kg = 0.88
52-54 kg = 0.90	56-58 kg = 0.92	60-62 kg = 0.96	64-66 kg = 0.98	68 kg = 0.99

In very young children (up to 1 year) a minimum dose of 20 MBq (10 MBq in thyroid scintigraphy) for direct administration or 80 MBq for red blood cell labelling is necessary in order to obtain images of sufficient quality.

### 5.3 Contraindications

Hypersensitivity to the active substance or any of the excipients.

### 5.4 Special warnings and precautions for use

This radiopharmaceutical may be received, used and administered only by authorized persons. Its receipt, storage, use, transfer and disposal are subject to the regulations and the appropriate licences of the local competent official organizations. Radiopharmaceuticals intended for administration to patients should be prepared by the user in a manner that satisfies both radiological safety and pharmaceutical quality requirements. Appropriate aseptic precautions should be taken, that comply with the requirements of Good Pharmaceutical Manufacturing Practice for pharmaceuticals.

During brain scintigraphy, pertechnetate uptake may occur in the plexus choroideus which might be misinterpreted as a damage of the blood brain barrier (false positive). To avoid such false positives and to minimize irradiation by reduction of pertechnetate accumulation in the thyroid and salivary glands, potassium perchlorate should be given prior to brain scintigraphy; (see also section 5.2). Potassium perchlorate blockade of thyroid and salivary glands should also be performed in lacrimal duct scintigraphy.

## **5.5 Interaction with other medicinal products and other forms of interaction**

Drug interactions have been reported in brain scintigraphy where there can be increased uptake of ( $^{99m}\text{Tc}$ ) pertechnetate in the walls of cerebral ventricles as a result of methotrexate-induced ventriculitis. In abdominal imaging drugs, such as atropine, isoprenaline and analgesics, can result in a delay in gastric emptying and redistribution of ( $^{99m}\text{Tc}$ ) pertechnetate.

## **5.6 Pregnancy and lactation**

### Pregnancy

$^{99m}\text{Tc}$  (as free pertechnetate) has been shown to cross the placental barrier.

When it is necessary to administer radioactive medicinal products to a woman of childbearing potential, information should always be sought about pregnancy. Any woman who has missed a period should be assumed to be pregnant until proven otherwise. Where uncertainty exists, it is particularly important that the radiation exposure should be the minimum consistent with achieving the desired clinical information. Alternative techniques which do not involve ionising radiation should be considered.

Radionuclide procedures carried out on pregnant women also involve radiation doses to the foetus. Only imperative investigations should be carried out during pregnancy, when the likely benefit exceeds the risk incurred by the mother and the foetus.

Direct administration of 800 MBq sodium pertechnetate ( $^{99m}\text{Tc}$ ) to a patient results in an absorbed dose to the uterus of 6.5 mGy. Following pretreatment of patients with a blocking agent, administration of 800 MBq sodium pertechnetate ( $^{99m}\text{Tc}$ ) results in an absorbed dose to the uterus of 4.8 mGy. Administration of 925 MBq  $^{99m}\text{Tc}$  labelled red blood cells results in an absorbed dose to the uterus of 3.6 mGy. Doses above 0.5 mGy should be regarded as a potential risk to the foetus.

### Lactation

Before administering a radioactive medicinal product to a woman who is breast-feeding, consideration should be given as to whether the investigation could be reasonably delayed until the mother has ceased breast-feeding and as to whether the most appropriate choice of radiopharmaceutical has been made. If the administration is considered necessary, breast-feeding should be interrupted for at least 12 hours and the expressed feeds discarded. Breast-feeding can be restarted when the activity level in the milk will not result in a radiation dose to the child greater than 1 mSv.

## 5.7 Effects on ability to drive and use machines

No studies on the ability to drive and use machines have been performed.

## 5.8 Undesirable effects

Information on adverse reactions is available from spontaneous reporting. The reported reaction types are anaphylactoid reactions, vegetative reactions, as well as different kinds of injection site reactions.  $^{99m}\text{Tc}$ -perchtechnetate from the UltraTechnekow FM generator is used for radioactive labeling of a variety of compounds. These pharmaceuticals generally have a higher potential for side effects than  $^{99m}\text{Tc}$ , and therefore the reported side effects are rather related to the labelled compounds than to  $^{99m}\text{Tc}$ . The possible types of side effects following intravenous administration of a  $^{99m}\text{Tc}$ -labelled pharmaceutical preparation will be dependent on the specific compound being used. Such information should be available from the manufacturer of the pharmaceutical which is to be radiolabelled.

### Anaphylactoid reactions:

Anaphylactoid reactions have been reported following intravenous injection of  $^{99m}\text{Tc}$ -perchtechnetate and include various skin or respiratory symptoms like skin irritations, oedema, or dyspnoea.

### Vegetative reactions (nervous system and gastrointestinal disorders):

Single cases of severe vegetative reactions have been reported, however, most of the reported vegetative effects include gastrointestinal reactions like nausea or vomiting. Other reports include vasovagal reactions like headache or dizziness. Vegetative effects are rather considered to be related to the examination setting than to technetium ( $^{99m}\text{Tc}$ ), especially in anxious patients.

### General disorders and administration site conditions

Other reports describe local injection site reactions. Such reactions are related to extravasation of the radioactive material during the injection, and the reported reactions rank from local swelling up to cellulitis. Depending on the administered radioactivity and the labeled compound, extended extravasation may necessitate surgical treatment.

The following table subsumes the observed reaction types and symptoms. Due to the fact that only spontaneous reports could be analysed, no frequency indications could be provided.

### Adverse Reactions sorted by System Organ Class

<u>Immune system disorders</u> Frequency unknown*: Anaphylactoid reactions (e.g. Dyspnoea, coma, urticaria, erythema, rash, pruritus, oedema at various location e.g. face oedema)
<u>Nervous system disorders</u> Frequency unknown*: Vasovagal reactions (e.g. Syncope, tachycardia, bradycardia, dizziness, headache, vision blurred, flushing)
<u>Gastrointestinal disorders</u> Frequency unknown*: Vomiting, nausea, diarrhoea
<u>General disorders and administration site conditions</u> Frequency unknown*: Injection site reactions (e.g. Cellulitis, pain, erythema, swelling)

\* Adverse reactions derived from spontaneous reporting

For each patient, exposure to ionising radiation must be justifiable on the basis of likely clinical benefit. The activity administered must be such that the resulting radiation is as low as reasonably achievable bearing in mind the need to obtain the intended diagnostic or therapeutic result. Exposure to ionising radiation is linked with cancer induction and a potential for development of hereditary defects.

For diagnostic nuclear medicine investigations, the current evidence suggests that these adverse effects will occur with low frequency because of the low radiation doses incurred. For most diagnostic investigations using a nuclear medicine procedure, the radiation dose delivered is less than 20 mSv (EDE). Higher doses may be justified in some clinical circumstances.

This product contains no ingredients that have a recognised action or effect, or knowledge of which is important for safe and effective use of the product.

## **5.9 Overdose**

In the event of the administration of a radiation overdose with sodium pertechnetate ( $^{99m}\text{Tc}$ ), the absorbed dose should be reduced where possible by increasing the elimination of the radionuclide from the body. Measures to reduce possible harmful effects include frequent voiding of urine and promotion of diuresis and faecal excretion. Very little supportive treatment can be undertaken in the event of an overdose of  $^{99m}\text{Tc}$ -labelled red blood cells since elimination is dependent on the normal haemolytic process.

## **6. PHARMACOLOGICAL PROPERTIES**

### **6.1 Pharmacodynamic properties**

Pharmacotherapeutic group: Various thyroid diagnostic radiopharmaceuticals

ATC code: V09F X01

No pharmacological activity has been observed in the range of doses administered for diagnostic purposes.

### **6.2 Pharmacokinetic properties**

The pertechnetate ion has similar biological distribution to iodide and perchlorate ions, concentrating temporarily in salivary glands, choroid plexus, stomach (gastric mucosa) and in the thyroid gland, from which it is released unchanged. The pertechnetate ion also tends to concentrate in areas with increased vascularisation or with abnormal vascular permeability, particularly when pre-treatment with blocking agents inhibits uptake in glandular structures.  $^{99m}\text{Tc}$  is selectively excluded from the cerebrospinal fluid. Following intravenous administration, pertechnetate ( $^{99m}\text{Tc}$ ) is distributed throughout the vascular system from which it is cleared by three main mechanisms:

- Rapid removal, depending on the diffusion equilibrium with interstitial fluid
- Intermediate rate of removal, depending on the concentration of the pertechnetate in glandular tissues, mainly thyroid, salivary and gastric fundus glands which have an ionic pump mechanism
- Slow removal, by glomerular filtration by the kidneys, dependent on rate of urinary excretion.

Plasma clearance has a half-life of approximately 3 hours. Excretion during the first 24 hours following administration is mainly urinary (approximately 25%) with faecal excretion occurring over the next 48 hours. Approximately 50% of the administered activity is excreted within the first 50 hours. When selective uptake of pertechnetate ( $^{99m}\text{Tc}$ ) in glandular structures is inhibited by the preadministration of blocking agents, excretion follows the same pathways but there is a higher rate of renal clearance. When pertechnetate ( $^{99m}\text{Tc}$ ) is administered in association with pre-treatment

with reducing agents such as stannous/medronate which cause a "stannous loading" of red blood cells, up to approximately 95% of the administered activity is taken up by the red blood cells where it becomes bound within the cells. Any unbound pertechnetate ( $^{99m}\text{Tc}$ ) is cleared by the kidneys; radioactivity in the plasma normally constitutes less than 5% of the intravascular activity. The fate of the technetium-99m follows that of the labelled erythrocytes themselves and the activity is cleared very slowly. A small level of elution of activity from the circulating red cells is thought to occur.

### **6.3 Preclinical safety data**

There is no information on acute, subacute and chronic toxicity from single or repeated dose administration. The quantity of sodium pertechnetate ( $^{99m}\text{Tc}$ ) administered during clinical diagnostic procedures is very small and apart from allergic reactions, no other adverse reactions have been reported.

Reproductive Toxicity: Placental transfer of  $^{99m}\text{Tc}$  from intravenously administered sodium pertechnetate ( $^{99m}\text{Tc}$ ) has been studied in mice. The pregnant uterus was found to contain as much as 60% of the injected  $^{99m}\text{Tc}$  when administered without perchlorate pre-administration. Studies performed on pregnant mice during gestation, gestation and lactation, and lactation alone showed changes in progeny which included weight reduction, hairlessness and sterility.

## **7. PHARMACEUTICAL PARTICULARS**

### **7.1 List of excipients**

- Sodium chloride
- Water for injections

### **7.2 Incompatibilities**

To date no incompatibilities are known.

### **7.3 Shelf life**

The expiry date for this product is 9 days after activity reference time.  
The eluate can be used for 8 hours.

### **7.4 Special precautions for storage**

Do not store above 25°C. Do not refrigerate.

Generators must be kept in an Ultra-TechneKow Safe (with sufficient lead protection) or behind an adequate laboratory shield.

The eluate should be stored at 2-8°C. Storage should be in accordance with national regulations for radioactive materials.

### **7.5 Nature and contents of container**

#### **Generator**

The generator consists of a cartridge containing an aluminiumoxide column charged with  $^{99}\text{Mo}$  and locked between two filters. One side of the cartridge is connected to the shielded, sterile supply needle in the eluent holder. The other side is connected to the similarly shielded, sterile outlet needle in the elution station. A second sterile needle in the eluent holder serves to eliminate the underpressure in the eluent vial under sterile conditions. The generator column is shielded by sufficient lead, depending on the  $^{99}\text{Mo}$  activity. The shielded generator with the built-in station and the eluent holder are packed in an hermetically sealed tin, which is also the package. Elution occurs by placing the eluent vial on the needles in the eluent holder, followed by complete or partial filling of evacuated vials.

### **Accessories**

The first time an Ultra-Technekow FM is supplied, it comes with:

- 1 TechneVial shield or UltraVial Shield
- 1 Sterile vial shielding, unless supplied with the Ultra-Technekow Safe.

Each Ultra-Technekow FM is supplied with:

- 7 TechneVials, sterile, evacuated vials of 5, 11 or 25 ml
- 1 Sterile vial is provided with the elution set.
- 1 Eluent vial, 100 ml of sterile, physiological salt solution
- 7 Disinfection swabs
- 7 Labels with the radioactivity symbol.

## **7.6 Special precautions for disposal and other handling**

Radiopharmaceutical agents should be used only by qualified personnel with the appropriate government authorizations for the use and manipulations of radionuclides. This radiopharmaceutical may be received, used and administered only by authorised personnel in designated clinical settings. Its receipt, storage, use, transfer and disposal are subject to the regulations and/or appropriate licences of local competent official organisations.

Radiopharmaceuticals should be prepared by the user in a manner which satisfies both radiation safety and pharmaceutical quality requirements. Appropriate aseptic precautions should be taken complying with the requirements of Good Pharmaceutical Manufacturing Practice for radiopharmaceuticals.

Any unused product or waste material should be disposed of in accordance with local requirements.

## **8. MANUFACTURED AND RELEASED BY**

Curium Netherlands B.V.  
Westerduinweg 3  
1755 LE Petten  
The Netherlands

## **9 INFORMATION OF PRODUCT REGISTRATION HOLDER**

Quantarad Technologies Sdn. Bhd.  
No. 18, 2nd floor, block B,  
Jalan PJU 1A/3,  
Taipan 2 Damansara, Ara Damansara, 47301  
Petaling Jaya, Selangor.



## 10. DATE OF REVISION

TO FILL AUTHORITY APPROVAL DATE

## 11. DOSIMETRY

According to the ICRP 80, the radiation doses absorbed by a patient following direct administration of sodium pertechnetate ( $^{99m}\text{Tc}$ ) are as follows:

### (I) Without pre-treatment with a blocking agent:

Organ	Absorbed dose per administered unit of activity (mGy/MBq)				
	Adults	15 years	10 years	5 years	1 year
Adrenal glands	0.0037	0.0047	0.0072	0.011	0.019
Bladder wall	0.018	0.023	0.030	0.033	0.060
Bone surfaces	0.0054	0.0066	0.0097	0.014	0.026
Brain	0.0020	0.0025	0.0041	0.0066	0.012
Breasts	0.0018	0.0023	0.0034	0.0056	0.011
Gallbladder	0.0074	0.0099	0.016	0.023	0.035
Gastrointestinal tract					
- Stomach wall	0.026	0.034	0.048	0.078	0.16
- Small intestine	0.016	0.020	0.031	0.047	0.082
- Colon	0.042	0.054	0.088	0.14	0.27
- Ascending colon wall	0.057	0.073	0.12	0.20	0.38
- Descending colon wall	0.021	0.028	0.045	0.072	0.13
Heart	0.0031	0.0040	0.0061	0.0092	0.017
Kidneys	0.0050	0.0060	0.0087	0.013	0.021
Liver	0.0038	0.0048	0.0081	0.013	0.022
Lungs	0.0026	0.0034	0.0051	0.0079	0.014
Muscles	0.0032	0.0040	0.0060	0.0090	0.016
Oesophagus	0.0024	0.0032	0.0047	0.0075	0.014
Ovaries	0.010	0.013	0.018	0.026	0.045
Pancreas	0.0056	0.0073	0.011	0.016	0.027
Red bone marrow	0.0036	0.0045	0.0066	0.0090	0.015
Salivary glands	0.0093	0.012	0.017	0.024	0.039
Skin	0.0018	0.0022	0.0035	0.0056	0.010
Spleen	0.0043	0.0054	0.0081	0.012	0.021
Testes	0.0028	0.0037	0.0058	0.0087	0.016
Thymus	0.0024	0.0032	0.0047	0.0075	0.014
Thyroid	0.022	0.036	0.055	0.12	0.22
Uterus	0.0081	0.010	0.015	0.022	0.037
Other tissue	0.0035	0.0043	0.0064	0.0096	0.017

<b>Effective dose (mSv/MBq)</b>	<b>0.013</b>	<b>0.017</b>	<b>0.026</b>	<b>0.042</b>	<b>0.079</b>
---------------------------------	--------------	--------------	--------------	--------------	--------------

**(II) With pre-treatment with a blocking agent:**

<b>Organ</b>	<b>Absorbed dose per administered unit of activity (mGy/MBq) when blocking agents are administered</b>				
	<b>Adults</b>	<b>15 years</b>	<b>10 years</b>	<b>5 years</b>	<b>1 year</b>
Adrenal glands	0.0029	0.0037	0.0056	0.0086	0.016
Bladder wall	0.030	0.038	0.048	0.050	0.091
Bone surfaces	0.0044	0.0054	0.0081	0.012	0.022
Brain	0.0020	0.0026	0.0042	0.0071	0.012
Breasts	0.0017	0.0022	0.0032	0.0052	0.010
Gallbladder	0.0030	0.0042	0.0070	0.010	0.013
Gastrointestinal tract					
- Stomach wall	0.0027	0.0036	0.0059	0.0086	0.015
- Small intestine	0.0035	0.0044	0.0067	0.010	0.018
- Colon	0.0036	0.0048	0.0071	0.010	0.018
- Ascending colon wall	0.0032	0.0043	0.0064	0.010	0.017
- Descending colon wall	0.0042	0.0054	0.0081	0.011	0.019
Heart	0.0027	0.0034	0.0052	0.0081	0.014
Kidneys	0.0044	0.0054	0.0077	0.011	0.019
Liver	0.0026	0.0034	0.0053	0.0082	0.015
Lungs	0.0023	0.0031	0.0046	0.0074	0.013
Muscles	0.0025	0.0031	0.0047	0.0072	0.013
Oesophagus	0.0024	0.0031	0.0046	0.0075	0.014
Ovaries	0.0043	0.0054	0.0078	0.011	0.019
Pancreas	0.0030	0.0039	0.0059	0.0093	0.016
Red bone marrow	0.0025	0.0032	0.0049	0.0072	0.013
Skin	0.0016	0.0020	0.0032	0.0052	0.0097
Spleen	0.0026	0.0034	0.0054	0.0083	0.015
Testes	0.0030	0.0040	0.0060	0.0087	0.016
Thymus	0.0024	0.0031	0.0046	0.0075	0.014
Thyroid	0.0024	0.0031	0.0050	0.0084	0.015
Uterus	0.0060	0.0073	0.011	0.014	0.023
Other tissue	0.0025	0.0031	0.0048	0.0073	0.013
<b>Effective dose (mSv/MBq)</b>	<b>0.0042</b>	<b>0.0054</b>	<b>0.0077</b>	<b>0.011</b>	<b>0.019</b>

The effective dose resulting from the administration of 800 MBq of sodium pertechnetate ( $^{99m}\text{Tc}$ ) is 10.4 mSv. After pretreatment of patients with a blocking agent, administration of 800 MBq of sodium pertechnetate ( $^{99m}\text{Tc}$ ) gives rise to an effective dose of 3.36 mSv.

The radiation dose absorbed by the lens of the eye following administration of sodium pertechnetate ( $^{99m}\text{Tc}$ ) for lacrimal duct scintigraphy is estimated to be 0.038 mGy/MBq.

(III) The radiation doses absorbed by a patient following intravenous injection of  $^{99m}\text{Tc}$  labelled red blood cells are as follows:

Organ	Absorbed dose per administered unit of activity (mGy/MBq)				
	Adults	15 years	10 years	5 years	1 year
Adrenal glands	0.0099	0.012	0.020	0.030	0.056
Bladder wall	0.0085	0.011	0.014	0.017	0.031
Bone surfaces	0.0074	0.012	0.019	0.036	0.074
Brain	0.0036	0.0046	0.0075	0.012	0.022
Breasts	0.0035	0.0041	0.0070	0.011	0.019
Gallbladder	0.0065	0.0081	0.013	0.020	0.030
Gastrointestinal tract					
- Stomach wall	0.0046	0.0059	0.0097	0.014	0.025
- Small intestine	0.0039	0.0049	0.0078	0.012	0.021
- Colon	0.0037	0.0048	0.0075	0.012	0.020
- Ascending colon wall	0.0040	0.0051	0.0080	0.013	0.022
- Descending colon wall	0.0034	0.0044	0.0069	0.010	0.018
Heart	0.023	0.029	0.043	0.066	0.11
Kidneys	0.018	0.022	0.036	0.057	0.11
Liver	0.013	0.017	0.026	0.040	0.072
Lungs	0.018	0.022	0.035	0.056	0.11
Muscles	0.0033	0.0040	0.0061	0.0094	0.017
Oesophagus	0.0061	0.0070	0.0098	0.015	0.023
Ovaries	0.0037	0.0048	0.0070	0.011	0.019
Pancreas	0.0066	0.0081	0.013	0.019	0.033
Red bone marrow	0.0061	0.0076	0.012	0.020	0.037
Skin	0.0020	0.0024	0.0038	0.0062	0.012
Spleen	0.014	0.017	0.027	0.043	0.081
Testes	0.0023	0.0030	0.0044	0.0069	0.013
Thymus	0.0061	0.0070	0.0098	0.015	0.023
Thyroid	0.0057	0.0071	0.012	0.019	0.036
Uterus	0.0039	0.0049	0.0074	0.011	0.019
Other tissue	0.0035	0.0045	0.0073	0.013	0.023
<b>Effective dose (mSv/MBq)</b>	<b>0.0070</b>	<b>0.0089</b>	<b>0.014</b>	<b>0.021</b>	<b>0.039</b>

The effective dose resulting from the administration of 925 MBq  $^{99m}\text{Tc}$ -labelled red blood cells is 6.48 mSv.

## 12. INSTRUCTIONS FOR PREPARATION OF RADIOPHARMACEUTICALS

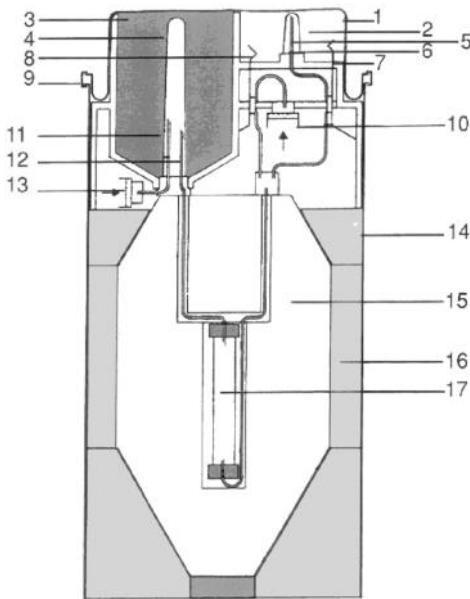

**Schematic of the Ultra-TechneKow® FM:**

- 1 Top cover
- 2 Elution station
- 3 Eluent vial chamber
- 4 Plastic cover for eluent needle
- 5 Rubber cover for eluate needle
- 6 Eluate outlet needle
- 7 Safety valve
- 8 Valve for partial elution
- 9 Lever closing ring
- 10 Air filter for partial elution
- 11 Inlet needle for sterile air
- 12 Eluent inlet needle
- 13 Air filter for eluent bottle
- 14 Containment
- 15 Lead shield
- 16 Support for lead shield
- 17 Generator column

### Instructions for use

The elution must be carried out in an area capable of maintaining the sterility of the generator.

### Preparation

- 1 Remove the seal, open the lever closing ring and store it together with the top cover.
- 2 Put the Ultra-TechneKow FM in the Ultra-TechneKow SAFE or behind any other suitable laboratory shielding with the elution station facing forward.

NB The needles are sterile beneath their covers and the generator underneath the top is clean, therefore disinfection with liberal amounts of disinfectants containing alcohol is undesirable and moreover may influence the pertechnetate ( $^{99m}\text{Tc}$ ) yield unfavourably.

- 3 Remove the flip-off cover from the capsule of the eluent vial, disinfect the stopper, remove (and store) the plastic cover of the inlet needle and lower the eluent vial into its holder.
- 4 Remove the flip-off cover from the capsule of the sterile vial and put it into the sterile vial shielding.
- 5 Remove (and store) the rubber needle protection from the outlet needle and lower the shielded sterile vial into the elution station.

### Elution

- 1 Remove the flip-off cover from the capsule of the required TechneVial, disinfect the stopper, let the disinfectant evaporate completely and put the vial into the UltraVial Shielding. (The TechneVial contains some residual water as a result of the sterilisation process.)
- 2 Replace the shielded sterile vial by the UltraVial Shield, ensure the lead glass window faces front.
- 3 Elution starts. The process can be interrupted depending on the required elution volume (Pertechnetate ( $^{99m}\text{Tc}$ ) concentration/ml). Elution is **always** ended by giving the UltraVial Shield a quarter turn, pushing it down and waiting for a few seconds (this causes the TechneVial to be filled with sterile air).
- 4 Replace the TechneVial Shielding by a shielded unused sterile vial.

**Never interrupt elution by lifting the TechneVial Shield without the quarter turn!**

**Eluates that are not clear or colourless must be rejected.**

**Disposal of waste and return of the generator**

- 1 Remove and dispose of the used sterile vial and the eluent vial.
- 2 Replace the original needle cover back on the inlet needles.
- 3 Elute the remaining millilitres of fluid from the generator (see under elution). The generator is now dry.
- 4 Replace the original outlet needle cover on the outlet needle.
- 5 Close the generator system with its top cover and lever closing ring.
- 6 Store the generator in a suitable place for decay to a level acceptable for disposal.

NB: In some countries the possibility exists to return expired generators. Consult the local representative for such a possibility or for details of dismantling.

The administration of radiopharmaceuticals creates risks for other persons from external radiation or contamination from spills of urine, vomiting etc. Radiation protection precautions in accordance with national regulations must therefore be taken.

Any unused product or waste material should be disposed of in accordance with local requirements.